

#Braumeister 1.000-litre

In response to many customer requests, we have now developed the 1000 litre Braumeister. This model is just right for anyone who wants to brew even more beer. The new touchscreen makes it easy to operate, and the sensor in the pressure line now allows the pump to be controlled by pressure in addition to speed. Even with a 1000 litre brew, the brewing process remains as simple as with the other big Braumeisters. And here too, the integrated timer function makes brewing easier because, for example, the brewing water can be heated up early in the morning.

The large malt pipe can also be easily lifted using the easy-to-operate crane with hand crank. The manhole facilitates access to the inside of the boiler. The Braumeister can be set up securely with its adjustable feet, but remains flexible due to its wheels. In spite of the impressive volume, even the very tall master brewer remains a compact brewing plant.

#BRAUMEISTER 1,000-LITRE

Model l	Item no.	Weight kg	Shipping weight kg
1,000	41000-20	850	980



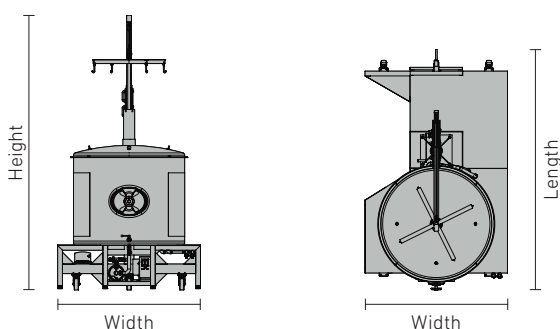
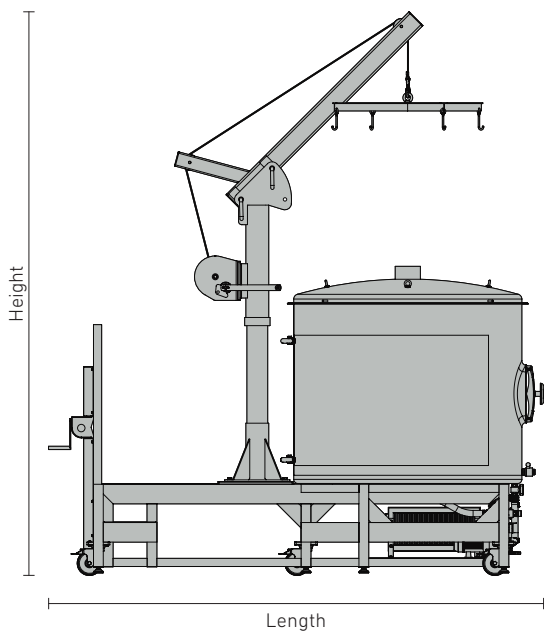

DIMENSIONS FOR #BRAUMEISTER 1,000-LITRE

Model	Length	Width	Height	Wooden crate
l	cm	cm	cm	l x b x h cm
1,000	305	180	345	310x190x195

TECHNICAL DETAILS #BRAUMEISTER 1.000-LITRE

- Heating coil: 12 x 3.000 W output
- Pump: 370 W
- Power supply connection: 400 V (fuse protection min. 63 A at star, delta connection not possible)
- Total power consumption: 38 kW
- Cooling: 2,56 m² double jacket surface, an additional heat exchanger plate for cooling is recommended
- Fully automated brewing regulation (temperature, time, pump)
- New Braumeister control with touchscreen
- Pressure sensor in the pressure line to control the pump also via pressure (or speed as before)
- Vaulted top with DN 150 connection piece for extractor hood and hop delivery opening
- Max. malt quantity: 225 kg